



Flexibility in order picking, storage and retrieval:
rail-guided stacker cranes

DAMBACH
LAGERSYSTEME

One concept – two series:
DAMBACH rail-guided stacker cranes



DAMBACH Lagersysteme has been building rail-guided stacker cranes for more than 35 years, and the company's many years of experience and innovative engineering place it among the market leaders. The cranes designed and built by DAMBACH are in use worldwide – because DAMBACH technology optimises any warehousing system! Our rail-guided stacker cranes with overall heights of 40 m and more are designed as fully automatic single- or twin-mast versions. They can be used as stand-alone units or as part of a complete system, with aisle-bound technology or as curve-going versions serving several aisles. And flexible modular systems enable us to incorporate bespoke adaptations and design individual solutions.

- High throughput rates
- High availability
- Best use of available space
- Shortest cycle times
- Modular system

**You name the loads:
DAMBACH handles them all!**

Whether a cheese wheel or a heavy machine part or a bulky carpet roll – only with the right loading auxiliaries and corresponding load-handling devices is it possible to operate a warehouse economically. Typical load-handling devices are telescopic forks for single- and double-deep storage. Double-deep storage increases the utilisation ratio for the available space. Rotating/traverse forks with adjustable tines permit the handling of both closed pallets and custom pallets with oversized dimensions. Modified load-handling devices and trays are available for special situations.

**Time-savings:
DAMBACH delivers!**

Good functionality is the key to a DAMBACH control, and its characteristics are fine-tuned to the requirements of DAMBACH stacker cranes. Absolute, contactless position decoding, path-dependent travel control and smooth acceleration are the features our customers have come to expect. Features that guarantee optimum performance. DAMBACH control components are available in several different configurations:

- Stacker cranes factory pre-wired
- Production and assembly of the control
- DAMBACH total control with hardware and software
- Materials-flow control

**Special requirements:
DAMBACH meets them!**

The technical requirements are as varied as the applications themselves. For example, with temperatures as low as -28° C in cold stores, not only the materials used, but also the manufacture, assembly and commissioning must be geared to those conditions. Maximum availability and reliability are key issues for car body storage prior to final assembly. For even minor disruptions can bring the production line to a standstill.

In order to do justice to these demands, quality in design is just as vital as quality in production. Our design work is therefore always carried out in 3D with movement simulation. And the finite element method (FEM) is used for the detailed design.

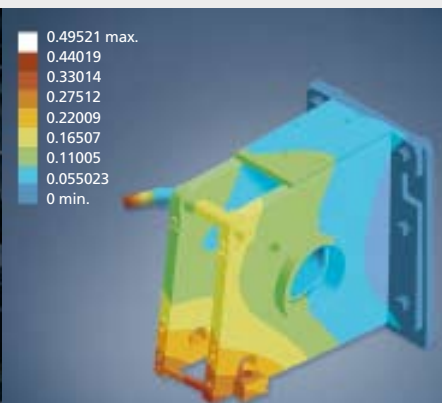

MULTI

The curve-going stacker cranes of the MULTI series are designed to work in more than one aisle. They can reach every storage aisle effortlessly.



Changing aisles: the easy way

The stacker cranes of the MULTI series offer users optimum solutions for changing aisles. Our stacker cranes are curve-going models that can change aisles directly via a point – without the need for a mechanical traverser. Operations are not interrupted, access times can be optimised. Every MULTI model can operate in more than one aisle. That means our customers can run large warehouses with just a few stacker cranes operating at maximum efficiency for maximum economy. An intelligent control coordinates the interaction of the various stacker cranes. In the case of a malfunction, one unit can take over the tasks of another and thus maintain the high availability of the warehouse. A further increase in performance is possible at any time by introducing further stacker cranes.

Less wear: patented rail geometry

The geometry of a conventional curved rail concept causes an inevitable lateral displacement of the running wheel. But this lateral displacement towards the inside of the curve results in substantial wear on running wheels and rails. For example, the displacement on an 800 mm radius curve amounts to about 12 mm! DAMBACH's patented curved rail configuration corrects this lateral displacement of the chassis. So you benefit from safe, low-wear guidance around the curves. At the beginning and end of each curve, the rails are offset slightly outwards in relation to the straight track. That prevents lateral displacement of the stacker crane, and cuts wear substantially

At a glance: the MULTI benefits

- Curve-going
- Aisle-changing via rails and points
- Patented rail geometry to minimise wear
- Operation of several MULTI stacker cranes without a fixed aisle allocation
- High availability of the warehouse thanks to variable aisle allocation
- Two driven wheels for good manoeuvring
- Integral stacker crane and point control
- Parameter-controlled operating strategy when using several stacker cranes
- Single- or twin-mast versions
- Overall heights up to 35 m
- Lifting capacities up to 4000 kg

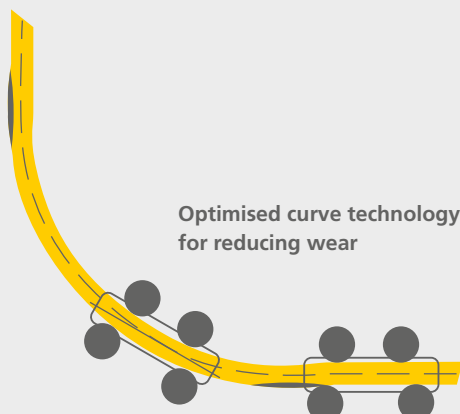

MONO

The rail-guided stacker cranes of the MONO series are aisle-bound models characterised by their excellent performance.



Aisle-bound: good space utilisation, fast movements

The aisle-optimised design of MONO stacker cranes gives them an extremely high space utilisation ratio. They benefit from minimum approach dimensions at the end of the aisle and at the top and bottom of the travel. The space utilisation ratio can be further improved depending on the particular application, e.g. by using a system without buffers at the end of the aisle.

The chassis of every DAMBACH rail-guided stacker crane can be adjusted and also allows infinite correction of the mast angle. That enables load cycle deformations to be compensated for safely and effectively. And that guarantees the accuracy of our stacker cranes even after many operating hours.

The low-vibration, rigid mast construction minimises the damping times between individual movements. Even high models achieve high speeds and good acceleration.

M-Class: modular design for maximum performance

When the specification calls for a particularly high throughput, our M-Class stacker cranes are the ones to choose – fitted with one or two drive units depending on requirements. If even greater productivity is required, a third drive unit can be added as well. And that results in a performance usually only seen in automated small parts warehouses.

The load-handling device is integrated directly into the lifting unit. That reduces the weight and ensures a particularly good telescoping performance.

Efficiency and reliability in continuous operation are guaranteed through a standardised modular system. Modules can be combined to suit the specification. That results in graduated, application-based stacker crane configurations. Subsequent performance upgrades can be achieved by retrofitting additional drives, for example.

At a glance: the MONO benefits

- Aisle-bound
- Minimum approach dimensions at the top and bottom of the travel
- No-buffers end-of-aisle protection
- Modular configuration
- Good speed and acceleration
- One, two or three drives depending on throughput requirements
- Low-vibration design
- Smooth running
- Adjustable drive unit heads
- Single- or twin-mast versions
- Overall heights up to 40 m
- Lifting capacities up to 4000 kg

DAMBACH Lagersysteme GmbH & Co. KG
Hardrain 1
76476 Bischweier
Germany
Tel: +49 (0)7222 9660-0
Fax: +49 (0)7222 9660-109
E-mail: info@dambach-lagersysteme.de
www.dambach-lagersysteme.de

Technical specification subject to change without notice

DAMBACH
LAGERSYSTEME